

## iDFace – Quick Guide

Thank you for purchasing iDFace! To access detailed information about your new product, please check the following link:

[www.controlid.com.br/userguide/idface-en.pdf](http://www.controlid.com.br/userguide/idface-en.pdf)

### Necessary Materials

In order to install your iDFace, you will need the following items: drill, wall plugs and screws, screwdriver or Philips, 12V power supply with at least 1A and an electronic lock.

### Installation

For the correct operation of your iDFace, the following precautions should be taken:

- Install in a place that is not exposed to direct sunlight. This lighting factor must be considered in order to ensure the great quality of the captured images.
- Avoid metallic objects near the rear of the device in order not to impair the proximity reader's range. In case this is not possible, use insulating spacers.
- Before securing the device in place, ensure all connecting cables are correctly routed towards the device.
- Fix the bottom part of the wall support for iDFace at 1.4m from the ground.

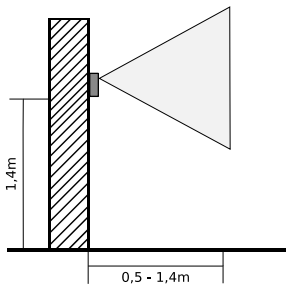

The device installation process is simple and should follow the diagram below:

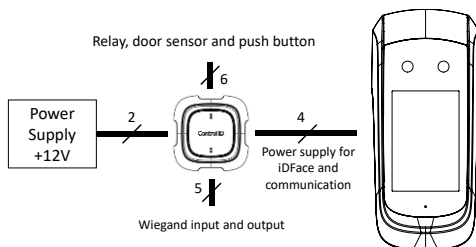

1. For greater security during the installation, place the External Access Module (EAM) in a secure region (internal area of the facility).
2. Use the reference pattern in the back of this guide to drill the 3 holes required to install the iDFace and fit in the wall plugs.
3. Connect the EAM to a +12V power source and to the lock, using the cables supplied.
4. Propose a 4 – way cable long enough to connect the EAM to the iDFace. For distances that are greater than 5m, use a twisted pair cable. Remember to use the same pair for signals A and B.

⚠ The EAM is responsible for powering iDFace.

5. Connect the wire harness provided with iDFace to the 4 wires in the previous item.
6. Remove the wall support from the iDFace.
7. Screw the wall support with the wall plugs.
8. Remove the sealing lid from the bottom and connect the 4-way wire to the iDFace.

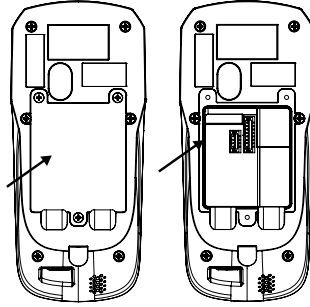

9. Replace and fix the lid and the sealing rubber.

⚠ The lid and the sealing rubber are essential for IP65 protection. Please make sure to position and fix them on the back of the product properly.

10. Secure the iDFace on the wall support and secure it in place with the screws provided together with the connection cables.

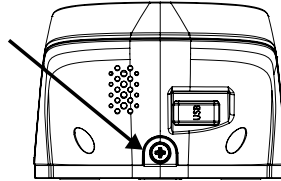

### Description of the Connection Terminals

On your iDFace, there is a connector on the back of the device, besides the network connector (Ethernet). In the External Access Module (EAM) there is a matching connector and 3 other connecting pins that will be used to connect locks, switches and scanners as explained ahead.

#### iDFace: 4 - Pin Connector

GND	Black	Power supply ground
B	Blue/Wh	Communication B
A	Blue	Communication A
+12V	Red	Power supply +12V

#### EAM: 2 - Pin Connector (Power Supply)

+12V	Red	Power supply +12V
GND	Black	Power supply ground

⚠ The connection to a +12V power supply with at least 1A is fundamental for the correct operation of the device.

#### EAM: 4 - Pin Connector

GND	Black	Power supply ground
B	Blue/Wh	Communication B
A	Blue	Communication A
+12V	Red	Output +12V

#### EAM: 5 - Pin Connector (Wiegand In/Out)

WOUT0	Yellow/Wh	Wiegand output - DATA0
WOUT1	Yellow	Wiegand output - DATA1
GND	Black	Ground (common)
WIN0	Green/Wh	Wiegand input - DATA0
WIN1	Green	Wiegand input - DATA1

⚠ External card readers should be connected to Wiegand WIN0 and WIN1. In case there is a control board, one can connect the Wiegand WOUT0 and WOUT1 outputs to the control board so that the user's ID identified in the iDFace is transferred to it.

#### EAM: 6 - Pin Connector (Door Control/Relay)

DS	Purple	Door sensor input
GND	Black	Ground (common)
BT	Yellow	Push button input
NC	Green	Normally closed contact
COM	Orange	Common contact
NO	Blue	Normally open contact

⚠ The push button and door sensor inputs can be configured as NO or NC and must be connected to dry contacts (switches, relays etc.) between the GND and respective pin.

### iDFace Settings

The configuration of all the parameters of your new iDFace can be set through the LCD display (Graphic of user Interface – GUI) and/or through a standard internet browser (as long as the iDFace is connected to an Ethernet network and has this interface).

In order to configure for example the IP address, subnet mask and gateway, through the touch screen, follow these steps: **Menu → Settings → Network**. Update the information as you wish and connect the device to the network.

### Web Interface Settings

First, connect the device directly to a PC using an Ethernet cable (cross or direct). Next, set a fixed IP on your computer for network 192.168.0.xxx (where xxx is different from 129 so that there is no IP conflict) and mask 255.255.255.0.

To access the device settings screen, open a web browser and enter the following URL: <http://192.168.0.129>

The login screen will be shown. The default access credentials are:

- Username: **admin**
- Password: **admin**

⚠ Through the web interface you can change the device's IP. If you change this parameter, remember to write down the new value so that you can connect to the product again.

### User Enrollment and Identification

The good working of the facial recognition system is directly related to the quality of the image captured by the iDFace during the enrollment stage. Thus, during this process, please make sure that the face is aligned to the camera and is 50 cm away. Avoid atypical facial expressions and objects that can hide important regions of the face (mask, sunglasses and others). Keep in mind that the enrollment picture must be taken as a personal document.

For the identification process, position yourself in front and inside the field of view of the iDFace's

camera and wait for the indication of access allowed or denied in the product's display.

⚠️ Avoid using objects that can block the capture of images of the eyes.

⚠️ The recommended distance between the device and the user (1.45 – 1.80m tall) is from 0.5 to 1.4 meters. Please make sure the client is positioned in the camera's field of view.

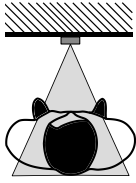

### Electronic lock types

iDFace, through the relay in the External Access Module, is compatible with almost all of the locks available in the market.

#### Magnetic lock

The magnetic or electromagnet lock consists of a coil (fixed part) and a metal part (armature plate) which is attached to the door (mobile part). While there is a current passing through the magnetic lock, the fixed part will attract the mobile part. When the distance between these two parts is small, ie. when the door is closed and the dock is on top of the fixed part, the attraction force between the parts can reach over 1000kgf.

Thus, the magnetic lock is normally connected to the NC contact of the activation relay, as we normally want for the current to go through the electromagnet and, if we want the door to open, the relay must open and interrupt the current flow.

In this guide, the magnetic lock will be represented by:

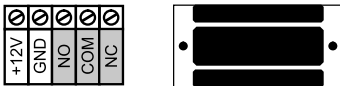

#### Electric bolt

The electric bolt lock, also known as solenoid lock, consists of a fixed part with a mobile pin connected to a solenoid. The lock normally comes with a metal plate that will be attached to the door (mobile part).

The pin on the fixed part enters the metal plate preventing the door from opening.

In this guide, the solenoid pin lock will be represented by:

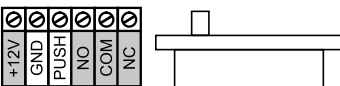

⚠️ The gray terminals may not be present in all locks. If there is a power supply connection (+ 12V or + 24V), it is essential to connect it to a source before operating the lock.

#### Electromechanical Lock

The electromechanical lock or strike lock consists of a latch connected to a solenoid through a simple mechanism. After opening the door, the mechanism

returns to its initial state allowing the door to be closed again.

Thus, the electromechanical lock typically has two terminals connected directly to the solenoid. When current passes through the lock, the door will be unlocked.

In this guide, the electromechanical lock will be represented by:



⚠️ Confirm the operating voltage of the lock before connecting it to the iDFace! Many electromechanical locks operate at 110V/220V and must therefore use a different wiring set up.

### Wiring Diagrams

#### iDFace and EAM (Mandatory)

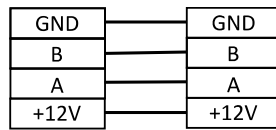

#### Door Sensor

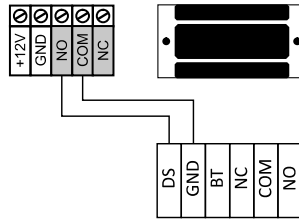

#### Push Button

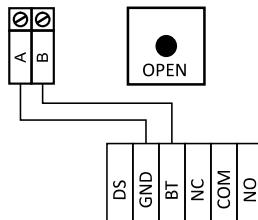

#### Magnetic Lock

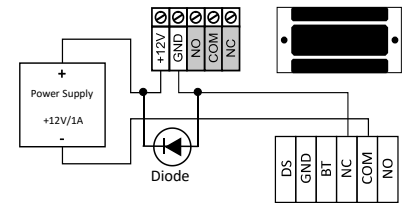

#### Solenoid Pin Lock (Fail Safe)

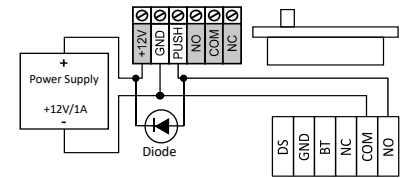

⚠️ We recommend the use of a dedicated power supply source to power the Solenoid Lock.

#### Electromechanical Lock (Fail Secure)

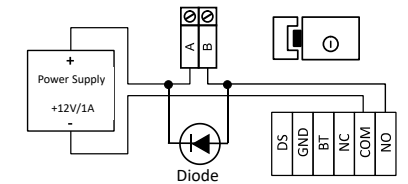

⚠️ We recommend the use of an exclusive power supply source to power the Electromechanical Lock.

### Reference pattern for installation

